

Application Description

STATIC REMOVAL UNWINDING PROCESS

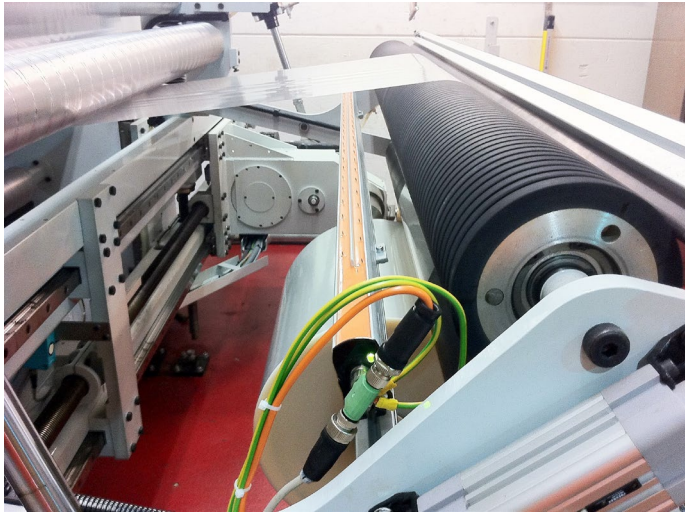

iONstream 4.0 network capable
AUTO DC Technology® static
neutralising system

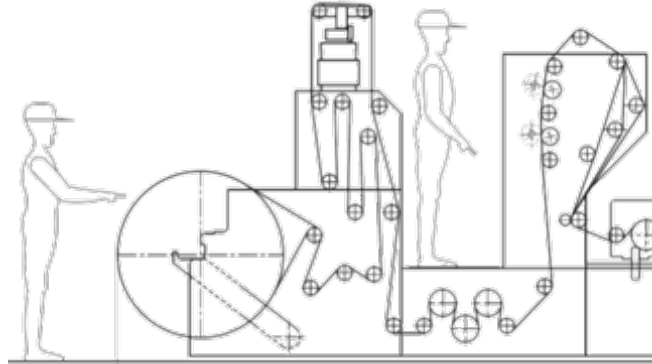

Application Information
STATIC CONTROL

Application Description

Winders are one of the most important types of machinery for static control equipment!

For operator safety and quality reasons, the substrate should be as much neutralized as possible to eliminate process problems and workers safety during the unwinding process. High web speeds and additional charging points, such as the rubber contact roller, demand the high efficiency static neutralizing system **iONstream 4.0**.

Key Features:

- 6, 12 or 18kV Ex and non Ex
- 24V DC supply, all HV parts integrated
- Up to 2000m/min line speed
- Visualisation of all parameter on touch panel PC
- Data logging for all parameters

Our product is the ideal solution for many substrates During the unwinding process:

- PE, PVC, PET
- Textile, Tissue, Nonwoven
- Paper, Cardboard

Find out more:

[iONstream 4.0 \(hildebrand-technology.com\)](http://iONstream.4.0(hildebrand-technology.com))

