

Application Success Stories

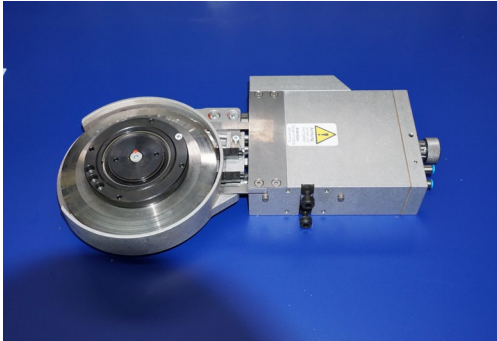

Technologies from Dienes and Hildebrand Technology complement each other perfectly in the production process.



Highest cutting accuracy

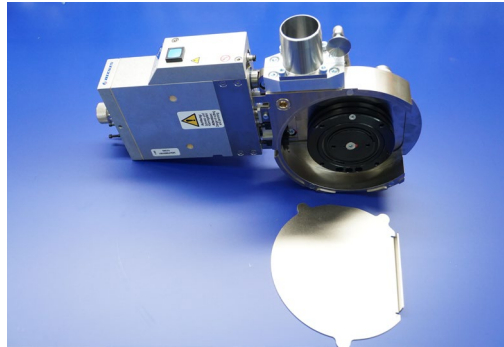

Efficient cutting dust extraction



Stable processes and improved product quality

Application Success Stories

Dienes knife with suction hood

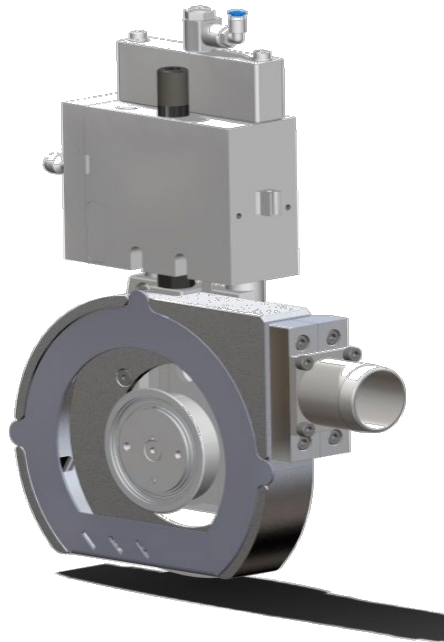

- ◆ Dust removal directly at the cutting blade
- ◆ High velocity vacuum air flow
- ◆ Up to 2500 m/min. line speed
- ◆ Retrofittable for almost any type of Dienes knife
- ◆ Toolless knife access
- ◆ Wear and maintenance free
- ◆ No build up of cutting particles and dirt on the knife
- ◆ Extension of the service life
- ◆ End product clean, compliance with various industry standards

Application Success Stories



Focusing on customers right from the start: The traditional company DIENES was founded in Remscheid in 1913 by Karl Rudolf Dienes. And even then, the goal was to adapt the cutting products and developments exactly to the requirements of the customers' requirements.

In this way, he laid the foundation for a globally successful development: The DIENES Group, now managed by the third generation of managing directors Bernd and Rudolf Supe-Dienes, is today the world's leading precision supplier in the fields of knives, knife holders and cutting systems for industrial

application, as well as the innovation partner for plate valves and regulators.

Application Success Stories

DIENES Werke für Maschinenteile GmbH & Co. KG

Kölner Straße 7
51491 Overath
Deutschland/Germany

Telefon: [+49 2206 605-0](tel:+4922066050)

E-Mail: sales@dienes.de



Hildebrand Technology Switzerland

Mövenstrasse 17
9015 St.Gallen
Switzerland

Telefon: +41 71 313 83 00

E-Mail info@hildebrand-technology.com